

- Sleeve manufacturers recommend storing sleeves vertically so that over time gravity does not cause them to lose roundness. Sleeves that go out of round are difficult or impossible to put on mandrels. **FLEXSTAND** stores sleeves vertically!
- System allows the storage of printing sleeves, bridge mandrels or anilox sleeves of any repeat or inside diameter.
- **FLEXSTAND** allows for sleeve centre distances to be infinitely adjustable to maximize storage efficiency.
- Sleeves are housed inside sturdy racks to protect them from damage.
- Racks are bolted to the floor; access is from both sides of each rack.
- All sleeves can be easily retrieved and are readily identifiable with a magnetic labelling system.
- Sleeves rest on a pad to prevent damage to the end of the sleeve and stabilize the bottom of the sleeve.
- Racking is of high strength via efficient use of sheet metal shelves and structural steel frames. All steel surfaces are powder coated for corrosion resistance.
- Smooth high gloss powder coated surfaces can easily be wiped down for cleaning.
- System is modular and can be expanded at any time.

Model Numbering Example

FS3V2H-35

FS = Flexstand 3 = Number of Bays Vertically 2 = Number of Bays Horizontally 35 = Maximum Repeat Sleeve that can be placed in the rack in inches

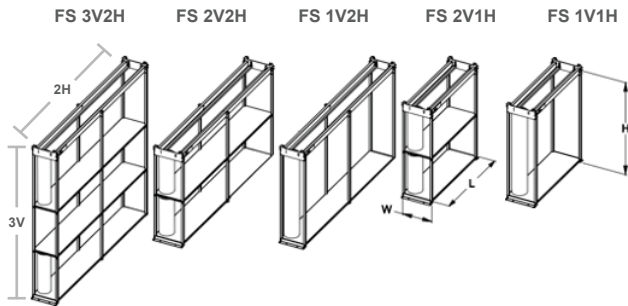

MODEL	LENGTH (L)		HEIGHT (H)		
	in	mm	info	in	mm
FS3V2H	142	3600	Total of three sleeve widths	+ 21	530
FS2V2H	142	3600	Total of two sleeve widths	+ 17	430
FS1V2H	142	3600	One sleeve width	+ 12	305
FS2V1H	75	1900	Total of two sleeve widths	+ 17	430
FS1V1H	75	1900	One sleeve width	+ 12	305

How do you Protect Sleeves?

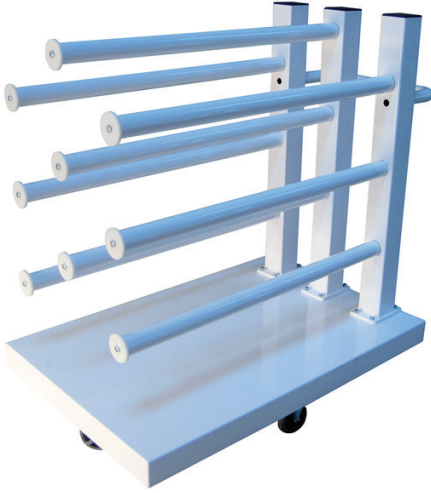

MAX REPEAT		WIDTH (W)	
in	mm	in	mm
22	560	14	355
30	760	19	480
33.5	850	21	540
40	1000	26	650
45	1150	29	740
55	1400	36	900

FLEXCARTH™ Print Sleeve Cart

- Built to suit 11 sleeves, 10 new ones for the press and one to take the first used sleeve off the press
- Standard sizes available for maximum 35 inch (900 mm) or 49 inch (1250 mm) repeat sleeves
- Unique castor design allows cart to turn about it's own centre in order to navigate in tight quarters
- Can be used for plate/print, anilox or bridge sleeve adaptors
- Horizontal rods are used to transport these sleeves around the plant so that they are easier to take off the carts and load them on the flexographic machine mandrel
- Custom cart designs are used to suit the sleeve width required
- Powder coated for durability and easy cleaning

FLEXCARTS™ Sleeve Scrub / Cleaning Cart

- Unique castor design allows cart to turn about it's own centre in order to navigate in tight quarters
- Stainless steel drip tray is resistant to cleaning materials & solvents
- A stainless steel ball valve allows draining of cleaning chemicals into a bucket for ease of disposal
- Powder coated for durability and easy cleaning
- Allows a quick scrub down of an anilox or print sleeve right next to the press or wheel it to a location that is more convenient
- Stainless steel drip tray is easily removed for pressure washing or machine washing
- Can be used for plate/print, anilox or bridge sleeve adaptors
- Custom cart designs are used to suit the sleeve width required

FLEXCARTA™ Air Shaft Cart

- Stores 4 six inch (150 mm) diameter & 4 three inch (75 mm) diameter airshafts
- Bottom tray allows the storage of chucks & adaptors
- Powder coated for durability and easy cleaning
- Improves employee safety by making shafts easier to move around the plant
- Can be easily wheeled to the unwind or rewinder location